

# CONVEYOR BELT SAFETY SWITCH

Ex tD A21 IP66 T85℃



## FLOW SWITCH

CONVEYOR BELT 라인에 측정물의 유량 및 레벨을 측정하는 장치이다.

Flow Switch is a device that checks flow and level of measured objects in CONVEYOR BELT line.



### ◆ 특징(Features)

- 본체는 알루미늄 구조로 설계된 제품으로 기계적강도가 우수함.  
Body is aluminum structure product and excellence in magnetic stress.
- 방수, 방진 기능이 우수하다.  
Excellence in water proof and vibration proof.
- PADDLE 재질은 현장조건에 따라 변경 사용이 가능하다.  
Material of PADDLE can be changed depending on field condition.
- 기술인증(Certification) : KTL
- 보호등급(Protection Class) : Ex tD A21 IP66 T85℃

### ◆ 기본사양 (Specification)

MODEL	WJL - FLS - B3EX
접점구성 (Contacts Composition)	접촉방식 (Contact method) : SPDT x 2 (2C/O)
접점용량 (Contacts Capacity)	AC/DC 250V 10A, 50/60Hz
동작각도 (Operation angle)	15° (±2°)
케이블인입구 (Cable Entry)	PF 3/4
적정온도 (Optimal Temperature)	-20℃ ~ +85℃
보호등급 (Protection Grade)	IP66
색상 (Color)	하마톤 IPH 노랑 (Hammerstone IPH Yellow)

### ◆ 결선도 (Connection)

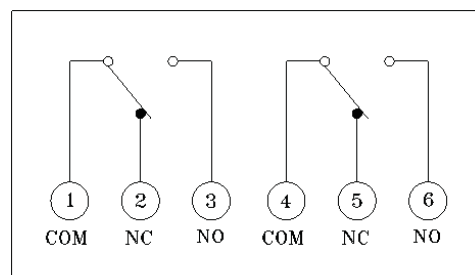

◆ 외형도(Outline Dimension)

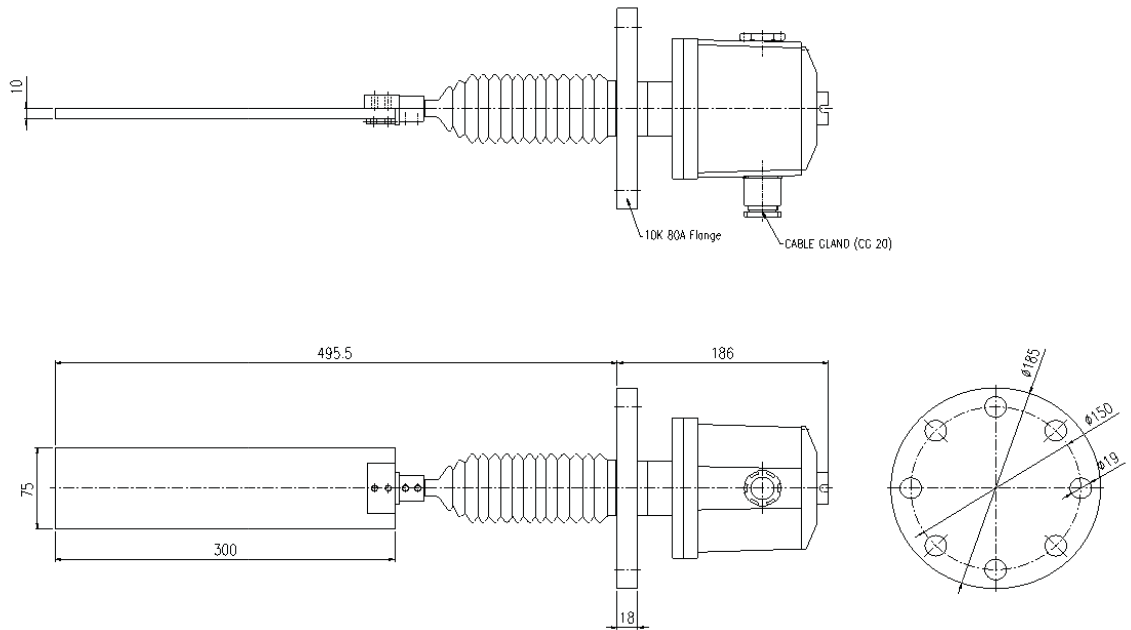

◆ 설치 예(Installation Example)

