

WIRE RUNNER

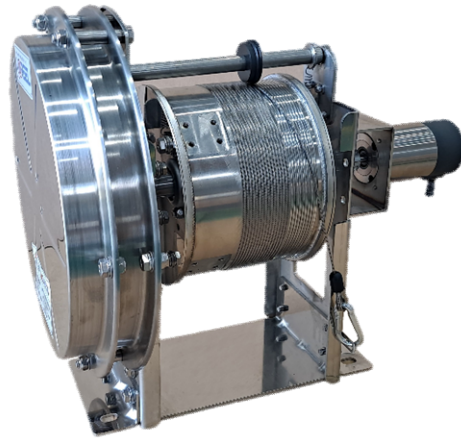

특 징 Feature

- ▶ 최장 40M 까지 검출할 수 있습니다.
→ Detection distance of up to 40m
- ▶ 와이어 선단을 이동체에 거는 것만으로 간단하게 위치검출할 수 있습니다.
→ Simply hook the end of the wire on the moving body for easy position detection.
- ▶ 와이어 고정으로 진동, 충격이 크더라도 센서부분이 손상될 걱정은 없습니다.
→ The sensor is impervious to vibration and impacts.
- ▶ 와이어 릴 몸체가 SUS304로 제작되어 부식에 강하다.
→ The wire reel body is made of SUS304, making it resistant to corrosion.

주요 특성 Specification

Item	Specifications				
Wire runner type	WJE-WR-OP-5	WJE-WR-OP-10	WJE-WR-OP-15	WJE-WR-OP-30	WJE-WR-OP-40
Winding unit material	Aluminum				
Built-in sensor type	MRE-32SP061		MRE-G64SP061		
Detection length	0~5m	0~10m	0~15m	0~30m	0~40m
Resolution	VS-10GH사용 : 0.079mm (4096/회전)		0.1538mm (2048/회전)	0.2441mm (2048/회전)	0.2441mm (2048/회전)
Linearity error [Max.]	±0.02 %	±0.01 %	±0.01 %	±0.01 %	±0.01 %
Reproducibility	±0.5 mm				
Wire gauge	2.0 mm				
Wire tension	4.0~16N(0.4~1.6Kgf)	5.5~21N(0.5~2.1Kgf)	5~25N(0.5~2.5Kgf)	12~22N(1.2~2.2Kgf)	12~22N(1.2~2.2Kgf)
Winding acceleration	50 m/s ²	30 m/s ²	30 m/s ²	20 m/s ²	20 m/s ²
Maximum usage rate	0.5 m/s				
Lifetime of winding springs	100만회	100만회	100만회	100만회	100만회
Ambient temperature	-20 ~ +80°C				
Protection structure (sensor body)	IP65				

형 식 Model

WJE-WR-OP-[①]-[②]

[①] : 검출 거리 Detection Distance

5: 5m , 10: 10m, 15: 15m 30: 30m 40: 40m

[②] : 센서 케이블 단말처리 Connection type of sensor cable

B : 표준컨넥터 Standard connector (NJW-2012PM8)

R : 압착단자 Crimping terminals

외형도 External Dimension

WJE-WR-OP (5~15M용)

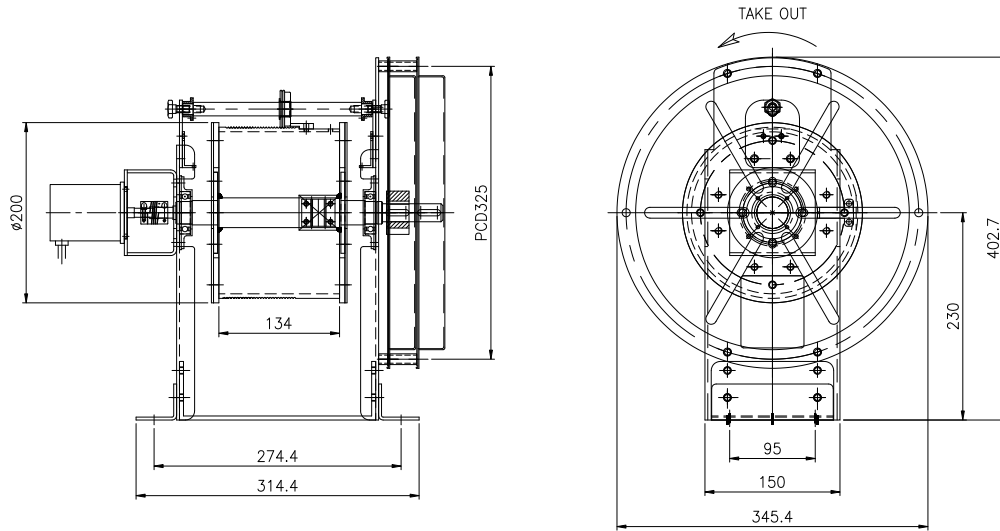

WJE-WR-OP (30~40M용)

